

PROJECT	QUANTITY	ITEM NO
---------	----------	---------

FlexFusion® Combi Oven/Smoker Gen 2 Platinum Series

FPE 621 G2 Electric
FlexiRack®+ Smoker



FLEXFUSION
PLATINUM



Henny Penny FlexFusion combi ovens combine different cooking methods into one piece of equipment with the flexibility to cook nearly everything on your menu to perfection.

The FlexFusion Smoker combi incorporates a powerful yet highly energy-efficient boilerless steam generation system that instantly adds or eliminates the precise amount of moisture needed to maintain desired cooking conditions... all while saving more energy and water than ever through an improved heat exchange design.

The Platinum Series features Chef'sTouch, an intuitive control system with a durable 7-inch touch/swipe screen that makes cooking with FlexFusion as easy as using a smart phone!

Chef'sTouch control: Just tap and swipe to run automated cooking and operating apps

Multi-sensor core temperature probe and USB port are standard.

Removable tilt-resistant rails accept 2/1 GN pans or 2 full-size steam table pans crosswise, or full-size sheet pans on wire shelves.

SmokeInside app

Add real smoke flavor in varying intensities to any cooking program

Other popular FlexFusion built-in apps:

- **PerfectHold**—Automatically switches to Hold when done cooking
- **TimeToServe**—Tells you when to load different items so they are all done at the same time
- **FamilyMix**—Shows which items can be cooked together
- **GreenInside**—Displays energy and water use for each cooking program
- **CombiDoctor**—Runs system self-diagnostics and displays results

Standard Features

- Chef'sTouch® Control System for Automatic or easy manual cooking
 - Durable 7-inch high resolution touch/swipe screen
 - Full-color display, video assist
 - Create your own recipes (up to 20 steps each) or select from 350 AutoChef cooking programs
 - Select and use apps for cooking, serving convenience, cleaning, diagnostics and more
 - Use ClimaSelect Plus to set and maintain humidity levels at 10% increments from 0% to 100% RH
 - Adjust individual settings before or during cooking
 - Multi-sensor food probe
 - Temperature in °F or °C
 - Choose language for operations and service diagnostics
- 6-level removable pan rack with tilt-resistant rails
- Lengthwise racking accepts 2/1 GN and full-size sheet pans
- DynaSteam2 precision boilerless steam generation with built-in energy-saving heat transfer
- 5-speed auto-reverse fan for fast, even cooking throughout the cabinet
- Steam Exhaust System (SES)
- Powerful high-efficiency motor uses up to 15% less energy
- Full perimeter door seal
- Triple-pane glass saves 28% more energy over ventilated door system
- Improved WaveClean® self-cleaning system uses 36% less water
- Retractable spray hose for quick, easy rinsing of interior
- Filterless grease extraction
- Stainless steel interior cabinet with coved corners
- 1 mm stainless steel exterior
- USB port for convenient download of programs, diagnostic messages or HACCP data

Options, accessories*

- Two-in-one cleaning cartridges
- Chicken grids
- Stands and cabinets
- Stacking kit
- Barcode scanning app

*See separate accessories data sheets for details

<input type="checkbox"/> APPROVED	<input type="checkbox"/> APPROVED AS NOTED	<input type="checkbox"/> RESUBMIT
AUTHORIZED SIGNATURE		DATE



FlexFusion® Combi Oven/Smoker G2

Platinum Series

FPE 621 G2 Electric
FlexiRack®+ Smoker

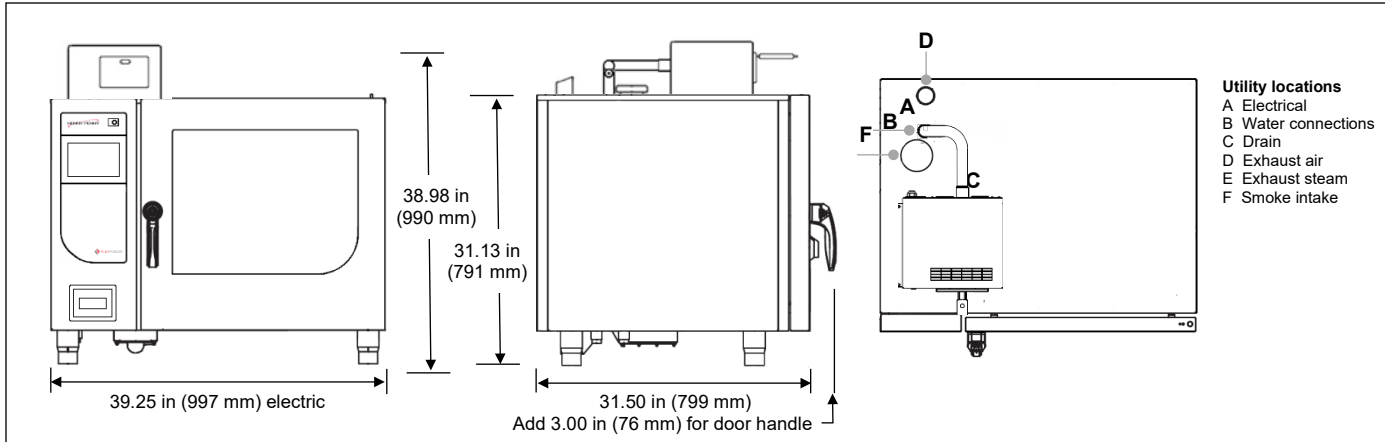

Dimensions

Height	31.13 in (791 mm)
Width	39.25 in (997 mm)
Depth	31.50 in (799 mm)

Crated

Length	43 in (1080 mm)
Depth	38 in (962 mm)
Height	40 in (1022 mm)
Volume	38 ft ³ (1.1 m ³)
Weight	375 lb (170 kg)

Required clearances

Left	20 in (500 mm) service access
Right	2 in (50 mm) air flow
Back	2 in (50 mm) air flow, utilities
Front	28 in (700 mm) door open

Softened drinking water connection

Water type	Softened drinking water, cold
Residual hardness CaCO ₃ (mmol/l (ppm))	< 1 (100 ppm)
Chloride Cl (mg/l)	< 100
Iron Fe (mg/l)	< 0.2
Connection pressure (kPa (psi))	200 (29) – 600 (87)
Connection (")	R 3/4

Drinking water connection

Water type	Drinking water, cold
Caronate hardness CaCO ₃ (mmol/l (ppm))	< 4 (400 ppm)
Connection pressure (kPa (psi))	200 (29) – 600 (87)
Connection (")	R 3/4

Electrical

Volts	Phase	Hertz	kW	Amps	Wire*
208	3	60	17.6	48.9	3+G
240	3	60	23.3	56.1	3+G
400	3	50/60	21.4	30.9	3NG
480	3	60	20.9	25.2	3+G

Heat (see also Cooking mode profiles)

Electric Max temperature 572°F (300°C)

Water

0.75 in standard cold water connection
0.75 in soft water connection
2.0 in (50 mm) drain

Capacity

- 6 full-size sheet pans 18 x 26 in (460 x 660 mm) lengthwise on wire shelves
- 12 full-size 2.5 in (65 mm) steam table pans crosswise, 2 per rail
- 4 standard 6-chicken grids crosswise, 2 per rail, 24 chickens per load

Cooking mode profiles

Steaming/moist heat
86-266°F (30-130°C)
Low and high temperature steaming
Convection cooking/dry heat
86-572°F (30-300°C) electric
Active humidity reduction
Combination/dry + moist heat
86-482°F (30-250°C)
Manual or automatic humidity control between 0 and 100% RH
Rethermalizing/dry + moist heat
86-356°F (30-180°C)
Special fan 5-speed function, banqueting programs

Bidding specifications

Provide Henny Penny FlexFusion Platinum Series FPE 621 electric combi oven, designed to cook with steaming/moist heat, convection/dry heat, or a combination of dry and moist heat, and holding up to 6 full-size sheet pans or 12 full-size steam table pans crosswise on removable tilt-resistant rails.

Unit shall incorporate:

- Chef's Touch Control System featuring protected full-color capacitive touch screen with automatic and manual cooking capability, ClimaSelect Plus humidity control and designated pre-loaded apps
- Boilerless DynaSteam2 Technology with precise humidity generation and heat exchange
- Variable speed, auto reverse fan that moves air in alternating directions for more even heating
- Automated WaveClean® self-cleaning system
- Seamless stainless steel cooking chamber, full-perimeter door seal and triple-pane glass for energy efficiency
- Cabinet exterior 20-gauge stainless steel

Laboratory certifications



*Units shipped without power cord and plug must have power cord and plug installed on site by a qualified electrician.

Continuing product improvement may subject specifications to change without notice.

24 Hour Technical Support:

Henny Penny Technical Service
800 417.8405
technicalservices@hennypenny.com

Henny Penny Corporation
PO Box 60 Eaton OH 45320 USA

+1 937 456.8400 800 417.8417
+1 937 456.8434 Fax 800 417.8434 Fax
www.hennypenny.com

HENNY PENNY