

| PROJECT | QUANTITY | ITEM NO |
|---------|----------|---------|
|---------|----------|---------|

Fryer Oil Disposal Shuttle

ODS 350



The unappealing job of draining, transporting and disposing of spent frying oil becomes much easier with the Henny Penny ODS 350 oil disposal shuttle.

Simply roll out the fryer filter pan, roll in the ODS 350 and drain. No tilting, stooping or lifting involved. A hinged lid latches shut to form a tight seal around the drain pan, preventing spills during transport. The load is easily transported on two large 7 in (178 mm) rear wheels.

A one-piece discharge pipe swings out to either side for convenient disposal. Manual pump is located at the ideal height, making pump out fast and easy.

The ODS 350 features a stainless steel drain pan and drain valve that allows for quick and easy disposal of water after cleaning the fryer. Located on the back of the drain pan the drain valve releases water into a floor drain avoiding the cast iron pump which would rust with exposure to water.

Standard Features

- Powerful manual pump empties 50 lb (23 kg) of oil in less than a minute
- Stainless steel drain pan
- Low profile, 8 in (203 mm) pan height allows unit to roll under nearly any compatible fryer for direct draining
- Check valve insures consistent pump priming
- One-piece discharge pipe swings at height to clear most containers
- Easy-grip retainer screw locks swing pipe into any convenient position
- Hinged drain pan lid latches closed over perimeter seal to prevent spills
- Rear drain valve for disposal of water
- Swivel casters in front, large 7 in (178 mm) rear wheels for smooth, stable transport
- 2-year parts/1-year labor warranty

Options

- 60 in (1524 mm) drain hose with connection
- Available without discharge pipe and manual pump (ODS350.03)

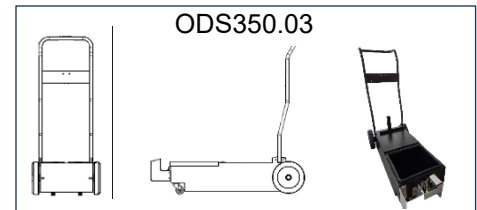
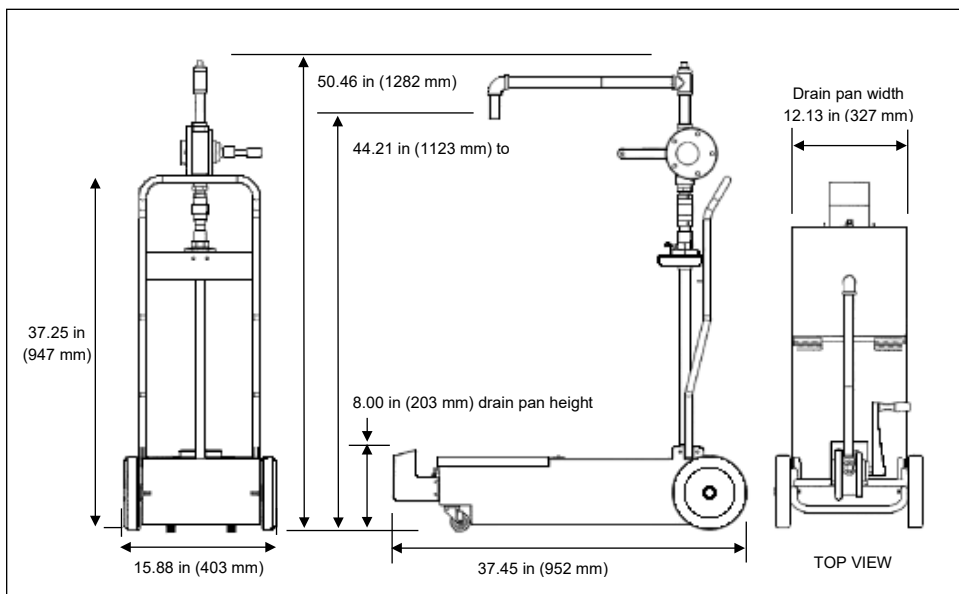

Dimensions

| | |
|---------------------|--------------------|
| Width | 15.88 in (403 mm) |
| Width drain pan | 12.13 in (327 mm) |
| Depth | 37.00 in (940 mm) |
| Height | 50.46 in (1282 mm) |
| Height to discharge | 44.21 in (1123 mm) |
| Height drain pan | 8.00 in (203 mm) |

Crated

| | |
|--------|--|
| Length | 30 in (762 mm) |
| Depth | 21 in (533 mm) |
| Height | 20 in (508 mm) |
| Volume | 7.3 ft ³ (0.20 m ³) |
| Weight | 62 lb (28 kg) |

Oil capacity

| |
|---------------|
| 50 lb (23 kg) |
|---------------|

*ODS350 Compatible with EEE14X, EEG24X, LVE20X, LVG20X and LVE30X products.

Continuing product improvement may subject specifications to change without notice.

24 Hour Technical Support:
Henny Penny Technical Service
800 417.8405
technicalservices@hennypenny.com

Henny Penny Corporation
PO Box 60 Eaton OH 45320 USA
+1 937 456.8400 800 417.8417
+1 937 456.8434 Fax 800 417.8434 Fax
www.hennypenny.com

HENNY PENNY
Engineered to Last