

PROJECT	QUANTITY	ITEM NO
---------	----------	---------

Rotisserie Mobile Stand

SCT 800



SCT 800 rotisserie mobile stand

This sturdy mobile work stand is designed specifically as a base for mounting the Henny Penny SCR 6 or SCR 8 countertop rotisseries when built-in countertops are not available.

Henny Penny mobile rotisserie stands provide foodservice operators a safe, sanitary surface to place rotisseries while making it easy to relocate them at any time for more efficient production or presentation.

Choose open stand or cabinet style with enclosed back and sides. Both styles include lower storage.

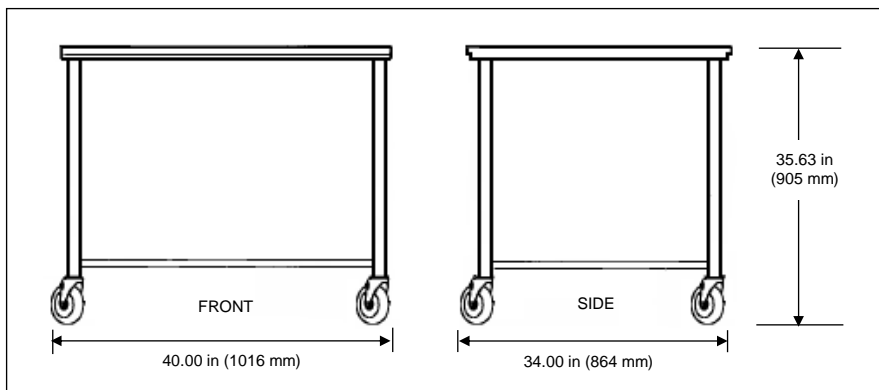

Standard Features

- Welded stainless steel construction for strength and easy cleaning
- Convenient lower storage shelf
- 4 heavy-duty swivel casters 5 in (127 mm) 2 locking
- Choose style
 - Table top with open sides and back
 - Cabinet-style with enclosed sides and back

Bidding Specifications

Provide Henny Penny rotisserie mobile stand model SCT 800 for SCR 6 or SCR 8 rotisserie.

Unit shall incorporate:

- High-quality welded stainless steel for strength and easy cleaning
- Lower storage shelf
- Choice of open or cabinet style
- Heavy duty locking casters

Laboratory certifications



Dimensions

Height 35.63 in (905 mm)
 Width 40.00 in (1016 mm)
 Depth 34.00 in (864 mm)

Crated

Length 48 in (1220 mm)
 Depth 37 in (940 mm)
 Height 48 in (1220 mm)
 Volume 50 ft³ (1.4 m³)
 Weight 104 lb (47 kg)
 Weight 132 lb (60 kg) with enclosed sides and back

Continuing product improvement may subject specifications to change without notice.

<input type="checkbox"/> APPROVED	<input type="checkbox"/> APPROVED AS NOTED	<input type="checkbox"/> RESUBMIT
AUTHORIZED SIGNATURE		DATE

Henny Penny Corporation
 PO Box 60 Eaton OH 45320 USA
 +1 937 456.8400 800 417.8417
 +1 937 456.8434 Fax 800 417.8434 Fax
 +1.800 417.8405 Technical Support
www.hennypenny.com

