



PAD7 Ambient Dough Drawers

STANDARD FEATURES

- Seven, ambient temperature dough drawers
- AISI, 20 gauge, 304 grade stainless steel interior and exterior (except galvanized steel exterior bottom)
- Casters – front locking
- Telescopic drawer guides extend from the cabinet to support the drawer when open
- Holds seven 18" x 26" pans (not included)
- Meets the guideline demands of HACCP

WARRANTY

- Two years warranty on parts



Locking front casters to keep unit in place

DOUGH DRAWER SPECIFICATIONS

Our ambient dough drawers, designed and manufactured with the highest quality materials, are an outstanding value.

The unit's seven ambient temperature drawers are designed to hold pizza dough, ingredients or utensils temporarily during the preparation period.

The unit may be purchased separately or as part of one of our complete specialty prep table units. This unit can be used for any prep table with an overall height of at least 34".

OUTSIDE DIMENSIONS

34.06" H x 23.22" W x 31.1" D

CAPACITY:

7 pans at 18" x 26" (pans not included)



Approval:
NSF 2: 2015

Date:
04/2018

Note: All specifications are subject to change without notice.



Proud to be family-owned.

PAD7 Ambient Dough Drawers

FRONT VIEW

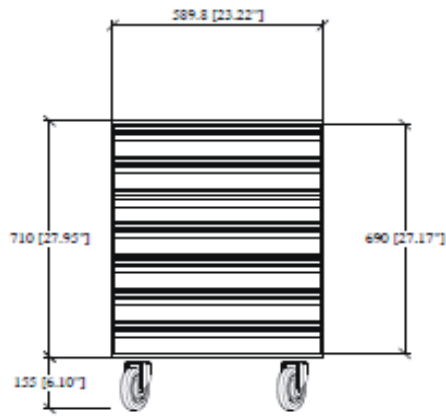

SIDE VIEW

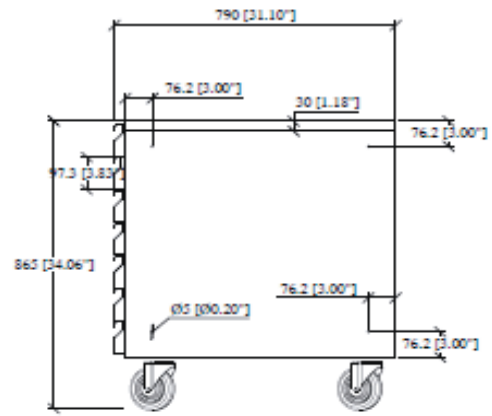

DRAWER DETAIL

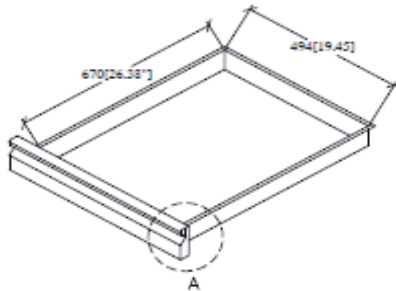

DRAWER FRONT DETAIL

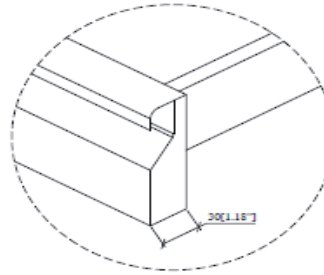

MODEL	DIMENSIONS				
	OUTSIDE			SHIPPING	
PAD7	WIDTH	DEPTH	HEIGHT	DIMENSIONS	WEIGHT
		23.22"	31.1"	34.06"	27" x 35" x 38"

Note: All specifications are subject to change without notice



CROWNTONKA[®] ICS[™] LOTEMP DOORS[™] PREPRITE[™] THERMALRITE[™]

Proud to be family-owned.